

**THE ONE IAQ SOLUTION FOR YOUR HOME!**

The APCO-ONE system is designed to improve air quality and HVAC equipment performance and efficiency. Everything you expect from APCO®, now with a polycarbonate housing and lamp status indicator. 24V with included 120V transformer.



**FEATURES/BENEFITS**

Continuously improves Indoor Air Quality	Continuously treats the air in the entire home and is virtually maintenance free (2-year UVC lamp replacement only)
Keeps coil & drain pan clean	Long lasting, safe and effective
Increases HVAC life & efficiency	For up-flow, down-flow & horizontal installations
UL2998 validated for zero ozone	Scientifically tested ensuring safety
Continuously treats the whole-system	Disinfects HVAC equipment (which is prone to mold and biofilm). Microbial contamination robs system efficiency and performance and contributes to poor IAQ
Advanced UVC lamp	2-year advanced encapsulated quartz UVC lamp
LED Lamp-life status indicator	Indicates when to replace lamp
EverCarbon™ Cells	Lifetime proprietary carbon catalyst
24VAC operation	Packard transformer included

**LED STATUS INDICATOR**



**SAFELY AND EFFECTIVELY TREAT THE OTHER 2/3RDS**

Conventional filters are only effective against particulates, like dust. APCO-ONE is proven to safely reduce both biological and chemical contaminants inside the air system and throughout the building. Together, they address 99+% of the contaminants in the air.

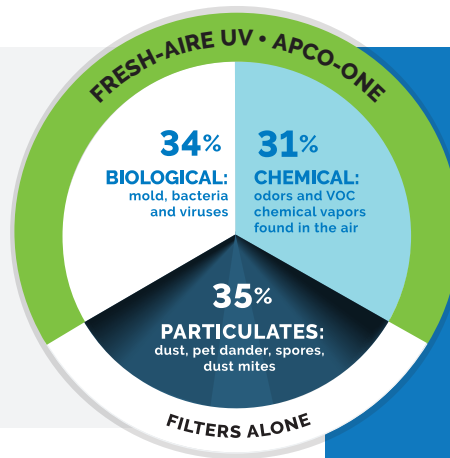

**CLEAN AIR**



**CLEANS THE COIL AND DRAIN PAN**

Helps keep the HVAC system running efficiently and extend its life.

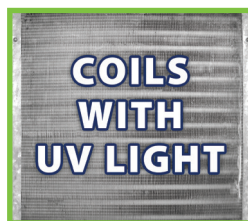
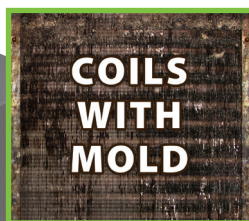

**APCO-ONE Helps Neutralize Mold, Bacteria, Viruses, and Allergens**

### APCO-ONE Specs

UV Lamp	254 nm UVC, quartz hot filament
Dimensions	Cell & Lamp: 3.3"W x 3.3"H x 14"D Enclosure: 6"L x 6"W x 2.43"D
Electrical	TUV-APCO-ONE: 24V, 0.80A, 19.2 WATTS
Transformer	Packard Transformer 120/208/240VAC Primary to 24VAC 40VA Secondary. For further instructions refer to transformer instruction sheet.
Pressure Drop	<0.01" w.c. @ 400 FPM
Warranty	Lifetime for all parts except lamp

### Part Numbers

Model	Electrical	Replacement Lamp
TUV-APCO-ONE	18-32 VAC	TUVL-215



APCO-ONE  
Furnace  
application

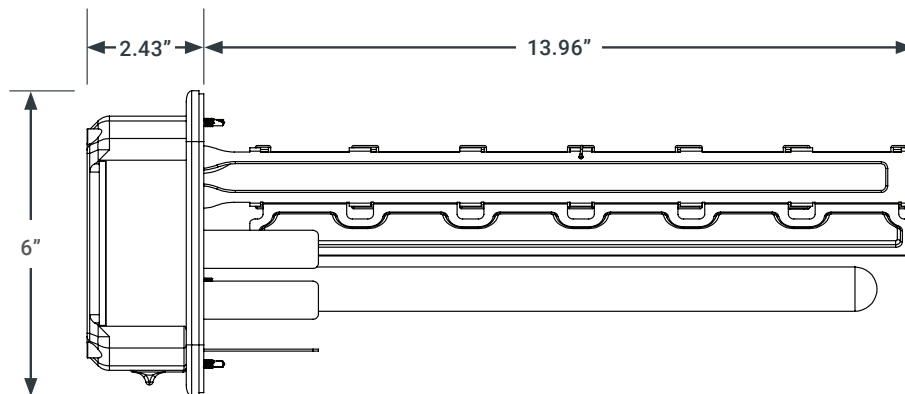
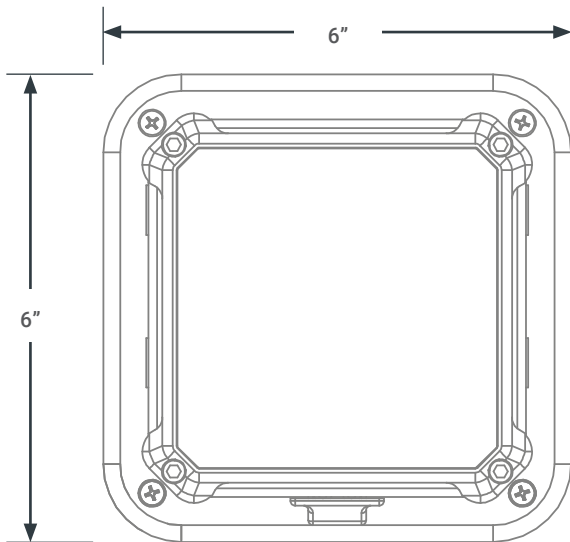

We are committed to developing and validating our products.  
APCO product testing achieved incredible results:

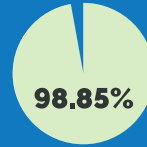

**98.85%**  
Bacteria  
(S.epideridis)\*

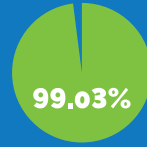

**99.03%**  
Viruses  
(MS2 coliphage)\*

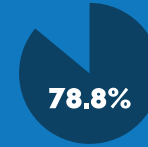

**78.8%**  
Mold  
(A.niger)\*

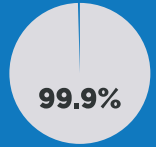

**99.9%**  
Odors  
(VOCs)\*

\* % Reduction of common indoor air contaminants over 4 hours.  
Tested at airflow velocity of 492-fpm (0.93m3/sec)



\* See manual for details



**DESIGNED & ASSEMBLED IN THE U.S.A.**